

# Audio Transformer 600Ω:600Ω

# B5104

Provisional Data Sheet

## Features

- Vacuum varnish impregnated
- Tested to 1000V DC isolation
- Internal Screen
- Flammability to UL94 V0

## Dimensions

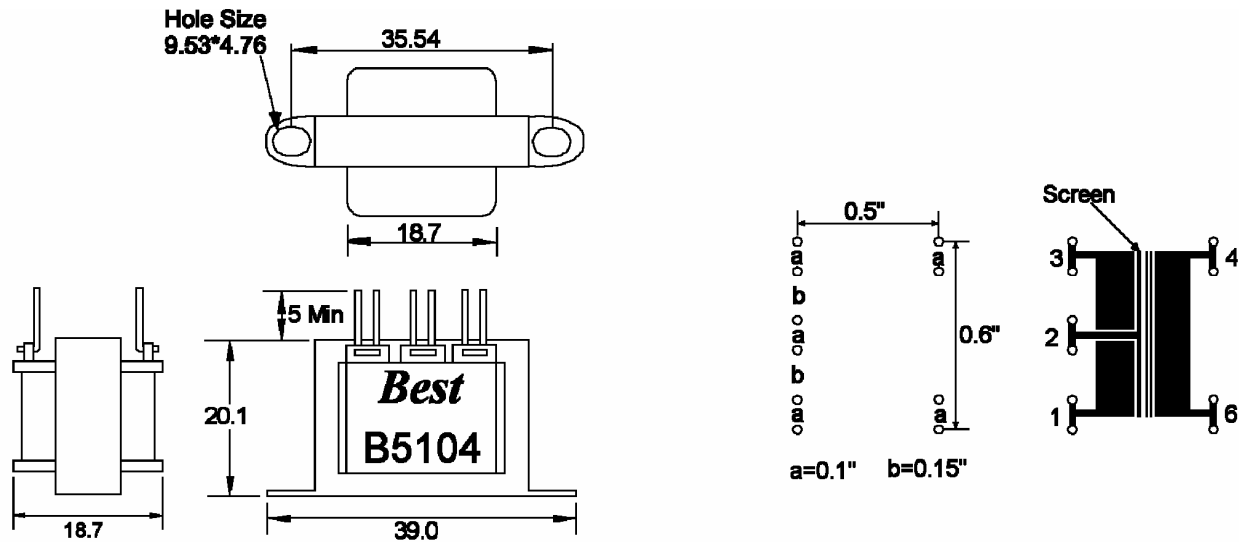

Dimensions in mm (Unless stated)

Tolerances  $\pm 0.1$  mm

Recommended clamping screw M3

## Technical Data

Parameter	Conditions	Value
Inductance pins 1-3	100 Hz 10 mV	1 H Typical
Leakage Inductance pins 1-3	10 kHz	550 $\mu$ H Typical
Ratio Pins 1-3 : 4-6		1 : 1
DC Resistance	Pins 1-3	3.2 $\Omega$ Typical
DC Resistance	Pins 4-6	4.8 $\Omega$ Typical
Isolation voltage	DC	1000 V
Operating Range	Ambient temperature	-10°C to 70°C
Functional		-40°C to 125°C
Storage		

**Best**  
**Windings Ltd**

[www.bestwindings.co.uk](http://www.bestwindings.co.uk)

Best Windings Ltd, Viking Works,  
Bucklesham Road, Kirton, Ipswich,  
Suffolk, England. IP10 0NX  
E-Mail: [sales@bestwindings.co.uk](mailto:sales@bestwindings.co.uk)  
Tel: + 44 (0) 1394 448 424  
Fax: + 44 (0) 1394 448 430

©The product numbers used are the trademarks of Best Windings Ltd  
©1997-2007 Best Windings Ltd. Reproduction Prohibited

November 2007